

Grayloc[®] Non-Slam Nozzle Check Valve

Innovative and unique check valve design with superior performance and reliability.

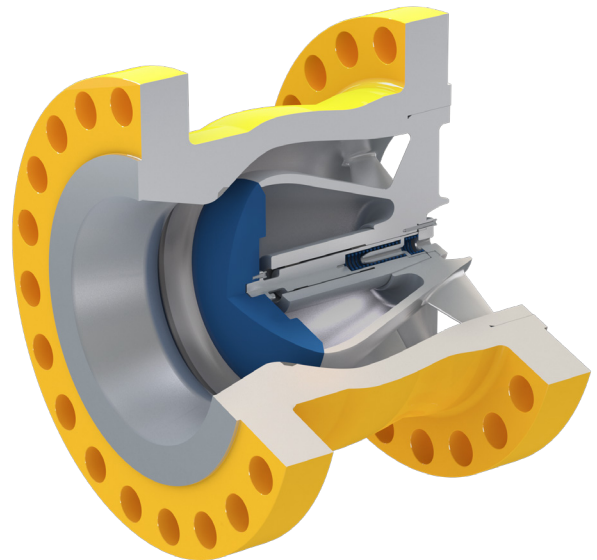

FEATURES

Low pressure loss

Unique dual spring for fast, non-slam response

Reliable, maintenance-free operation

Grayloc® Non-Slam Nozzle Check Valve

Our non-slam nozzle check valve*, characterized by an optimized flow profile and unique dual-spring design, solves common check valve operational issues while improving on the dynamic response and pressure loss of existing nozzle check valve designs. Low friction movement, low part weight, and short disc stroke ensure stable, maintenance-free operation, even in low flow applications. The simplified, one-piece valve body with an integral valve seat is inherently fire-safe, and is customizable to meet internal coating, length, and end-connection requirements.

Industries and Applications

- » Compressor Stations
- » Cryogenic
- » Desalination
- » Natural Gas, Water, Oil, and Fuel Pipelines
- » Nuclear
- » Refineries
- » Subsea
- » Water Management

Design Parameters

Nominal pipe size (NPS)	1 to 72 in
End connections	Grayloc clamp connectors and compact flanges, ASME B16.5 flanges, ASME B16.47 flanges, ASME B16.25 weld ends, NORSOK L-005 compact flanges, AS4087 flanges, and API 6A flanges. Other end connections available upon request.
Design pressure rating	Suitable for ANSI Class 150 up to 10,000 psig
Design temperature range	Per material limit (full metal construction)
Flow orientation	Up, down, diagonal, and horizontal

Material Specifications

Body (forged or cast)	Nickel alloys, carbon, low-alloy, stainless and duplex stainless steels
Disc (forged or cast)	Nickel alloys, carbon, low-alloy, stainless and duplex stainless steels
Body seat	All API trims. Custom trims available upon request.
Disc seat	All API trims. Custom trims available upon request.
Internal coating	Fusion bonded epoxy or as specified by customer
External coating	Per customer specifications

Applicable Design Codes, Standards, and Specifications (latest editions)

ASME B16.34, Valves - Flanged, Threaded, and Welding End
ASME B16.10, Face-to-Face and End-to-End Dimensions of Valves
AS4794, Non-Return Valves for Waterworks Purposes
API 6A, Specification for Wellhead and Christmas Tree Equipment
API 6D, Specification for Pipeline Valves
API 594, Check Valves: Flanged, Lug, Wafer and Butt-Welding
API 598, Valve Inspection and Testing

*Formerly the SMX Non-Slam Nozzle Check Valve

■ For more information, visit oceanengineering.com/grayloc or contact us at graylocproducts@oceanengineering.com

© 2023 Oceanengineering International, Inc. All rights reserved.