

## Features:

- Excitation system: self-excited (AREP and PMG are optional)
- ATS (automatic transfer switch) receptacle
- Lockable battery isolator switch
- Stainless galvanized zinc plates with strong corrosion resistance
- Vibration isolators between the engine/alternator and base frame
- Integrated wiring design
- Base fuel tank for at least 8 hours running
- Equipped with an industrial muffler
- Engine oil pump
- 50 C radiator
- Top lifting and steel base frame with forklift holes
- Drainage for fuel tank
- Complete protection functions and safety labels
- IP54 (soundproof sets), IP56 (control system)
- Water jacket preheater, oil heater and double air cleaner, etc. are available.



### Output Ratings

Generating Set Model	Prime	Standby
<b>WPS300/S</b>	300kVA/240kW	330kVA/264kW

Ratings at 0.8 power factor.

### Ratings and Performance Data

<b>Engine Make &amp; Model:</b>	1506A-E88TAG5	
<b>Alternator Model:</b>	LSA46.3L10	
<b>Alternator Brand:</b>	Leroy Somer	
<b>Control System:</b>	PLC-920 / PLC-7420	
<b>Noise Level @7m:</b>	/	
<b>Circuit Breaker Type:</b>	/	
<b>Frequency &amp; Phase:</b>	50Hz & 3PH	
<b>Engine Speed: RPM</b>	1500	
<b>Structure Type:</b>	<b>WPS300</b>	B
	<b>WPS300S</b>	R
<b>Fuel Tank Capacity: L</b>	<b>WPS300</b>	775
	<b>WPS300S</b>	730
<b>Fuel Consumption: l/hr (100% Load)</b>	<b>Prime</b>	/
	<b>Standby</b>	/

### Dimensions and Weights

Generating Set Model	Length (L) mm (in)	Width (W) mm (in)	Height (H) mm (in)	Dry kg (lb)	Wet kg (lb)
<b>WPS300</b>	3250	1050	2100	2800	/
<b>WPS300S</b>	4525	1400	2250	4150	/

Dry = With Lube Oil      Wet = With Lube Oil and Coolant

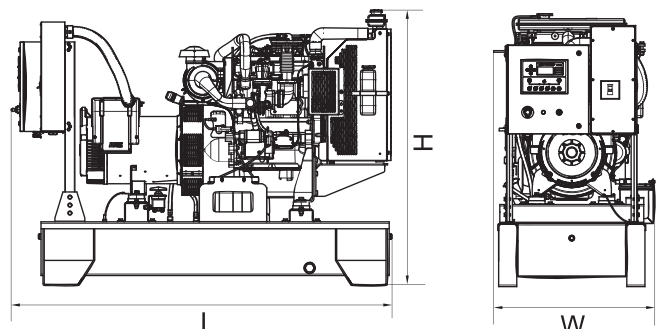
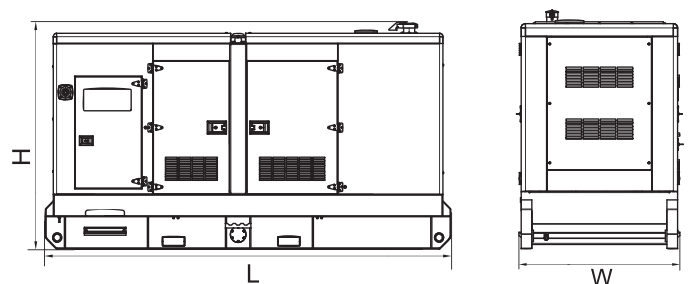

Also available in the following voltages: 415/240V-380/220V-220/127V-200/115V;

ESP: Standby Power Standby duty, operation under variable load, without over load;

PRP: Prime Power-Continuous duty operation, under variable load 24/24h-10% over load permissible 1 hour/12 hours;

The data is only for your reference but not for use of sales.

M: Mechanical speed governor, E/ECU: Electronic speed governor;

NA: Naturally aspirated, TC: Turbocharged, TCA: Turbocharged and air-air aftercooled. TCW: Water-cooled Turbocharged;

The weights are approximate and without fuel.

## Engine model: 1606A-E93TAG5

### Cooling system

For details of recommended coolant specifications, refer to the Operation and Maintenance Manual for this engine model.

Total coolant capacity	30.9 litres
-engine	11.8 litres
-radiator	15.5 litres
-pipes and hoses	3.6 litres
Maximum pressure in engine cooling circuit	530 kPa
Maximum top tank temperature	107°C
Maximum static pressure head on pump	107 kPa
Thermostat operating range	86 - 96°C
Coolant flow, against 30 kPa restriction 1,500 rpm	360 litres/min
Maximum temperature rise across the engine	8°C

### Radiator

Radiator face area	0.622 m <sup>2</sup>
Number of rows and material	4 (64 / Row) Al
Fins per inch and material	10 Al
Pressure cap setting (min)	110 kPa

### Charge cooler

Face area	0.378 m <sup>2</sup>
Number of rows and material	2 (19 / Row) Al
Fins per inch and material	10 Al

### Width and height of matrix

Height	1318 mm
Width	1071 mm
Weight of cooling pack (dry)	82.64 kg

### Coolant pump

Method of drive ... Belt driven

### Fan type/details

Diameter	36 inch (914 mm)
Drive ratio	1:1
Material	Plastic
Number of blades	5
Pusher/puller	Pusher
Cooling fan air flow @ 1500 rpm	609 m <sup>3</sup> /min

### Fuel consumption

**Note:** All figures based on Nett power.

#### 1606A-E93TAG5

Rating	g/kWh	l/hr
	1500 rpm	
Standby	198	66
Prime	200	61
75% prime	208	47
50% prime	223	34

#### 1606A-E93TAG4

Rating	g/kWh	l/hr
	1500 rpm	
Standby	200	61
Prime	202	56
75% prime	211	44
50% prime	228	32

### Duct Allowance

Ambient cooling clearance (standby power) based on air temperature at fan of 7°C above the ambient.

Maximum additional restriction (duct allowance) to cooling airflow and resultant minimum airflow.

Description	@ 1500 rpm	
	Ambient clearance	42
Duct allowance	12.5	mm.wg
Minimum airflow at conditions	480	m <sup>3</sup> /min
Ambient clearance	50	°C
Duct allowance	20	mm.wg
Minimum airflow at conditions	426	m <sup>3</sup> /min

### Normal operating angles:

-front and rear	± 5°
-side tilt	± 5°

### Fuel system

Injection system	Direct
Injector type	Hydraulically Actuated Electronically Controlled Unit Injector
Governor type	Electronic (isochronous or droop capability)
Recommended fuel to conform to	BS 2869 1998 CLASS A1, CLASS A2 or BSEN590
Injector pressure	193 MPa
Lift pump type	Bosch 24P320
Lift pump fuel delivery @ 1500 rpm	73.8 litres/hour
Lift pump delivery pressure	482 kPa
Maximum suction head at pump inlet	1 m
Maximum static pressure head	517 m
Maximum fuel inlet temperature	TBA °C
Fuel filter spacing	7 microns
Tolerance on fuel consumption	5%
Heat retained in fuel to tank	TBA kWt

### Lubrication system

Total lubrication system capacity (dry engine)	36 litres
Total lubrication system capacity (oil change)	33 litres
Oil temperature (in sump) maximum	132°C
Oil temperature (in sump) normal continuous operation	121°C
Shutdown switch setting (where fitted)	kPa falling
Lubricating oil pressure at bearings:	
-at rated 1500 rpm (normal)	379-413 kPa
Minimum	241 kPa
Oil relief opens at	345 kPa
Oil filter screen spacing	20 microns
Lubricating oil flow at 1500 rpm	105 litres/min.
Oil consumption	<0.1% of fuel
Oil pump speed (gear driven)	1500 rpm

### Induction system

Maximum air intake restriction of engine:

Clean filter	2.50 kPa
Dirty filter	6.22 kPa
Induction indicator setting	TBA kPa
Air filter type	Dry paper element

## Alternator model: LSA46.2VL12

### SPECIALLY ADAPTED FOR APPLICATIONS

The LSA 46.2 alternator is designed to be suitable for typical generator applications, such as: backup, standard production, cogeneration, marine applications, rental, telecommunications, etc.

### COMPLIANT WITH INTERNATIONAL STANDARDS

The LSA 46.2 alternator conforms to the main international standards and regulations:

IEC 60034, NEMA MG 1.22, ISO 8528, CSA/UL on request, marine regulations, etc.

It can be integrated into a CE marked generator.

The LSA 46.2 is designed, manufactured and marketed in an ISO 9001 and ISO 14001 environment.

### TOP OF THE RANGE ELECTRICAL PERFORMANCE

- Class H insulation.
- Standard 12-wire re-connectable winding, 2/3 pitch, type no. 6 .
- Voltage range: 220 V - 240 V and 380 V - 415 V (440 V) - 50 Hz / 208 V - 240 V and 380 V - 480 V - 60 Hz.
- High efficiency and motor starting capacity.
- Other voltages are possible with optional adapted windings:
  - 50 Hz: 440 V (no. 7), 500 V (no. 9), 600 V (no. 23), 690 V (no. 10 or 52)
  - 60 Hz: 380 V and 416 V (no. 8), 600 V (no. 9).
- THD Total harmonic distortion < 2,5% (full load).
- R 791 interference suppression conforming to standard EN 55011 group 1 class B standard for European zone (CE marking).

### EXCITATION AND REGULATION SYSTEM SUITED TO THE APPLICATION

Excitation system				Regulation options				
Voltage regulator	SHUNT	AREP	PMG	T.I. Current transformer for paralleling	R 726 Mains paralleling	R 731 3-phase sensing	R 734 3-phase sensing on mains paralleling unbalanced	P Remote voltage potentiometer
R 250	Std	-	-	-	-	-	-	√
R 450	optional	Std	Std	√	√	√	√	√
D 510	optional	optional	optional	√	included	included	contact factory	√

Voltage regulator accuracy +/- 0.5%.

√ : possible mounting

### PROTECTION SYSTEM SUITED TO THE ENVIRONMENT

- The LSA 46. 2 is IP 23.
- Standard winding protection for clean environments with relative humidity ≤ 95 %, including indoor marine environments.
- Options: - Filters on air inlet : derating 5%
  - Filters on air inlet and air outlet (IP 44) : derating 10%.
  - Winding protections for harsh environments and relative humidity greater than 95%.
  - Space heaters.
  - Thermal protection for windings and shields.

### REINFORCED MECHANICAL STRUCTURE USING FINITE ELEMENT MODELLING

- Compact and rigid assembly to better withstand generator vibrations.
- Steel frame.
- Cast iron flanges and shields.
- Twin-bearing and single-bearing versions designed to be suitable for engines on the market.
- Half-key balancing.
- Greased for life bearings (regreasable bearings optional).

### ACCESSIBLE TERMINAL BOX PROPORTIONED FOR OPTIONAL EQUIPMENT

- Easy access to the voltage regulator and to the connections.
- Possible clusion of accessories for paralleling, protection and measurement.
- 12 way terminal block for reconnecting voltage reconnection.

WPS300 / WPS300S

# Control System PLC-920 (Optional)

PowerLink PLC-920 generator controllers integrating digital, intelligent and network techniques are used as the automatic control systems for diesel generators. It can carry out functions including pre-alarm, warning & electrical trip, fail monitoring and controls etc.

## FEATURES

- Parameter configuration via RS-232 serial communication;
- Log last 50 events & alarm information with measured values;
- Statistics records;
- Remote start/stop;
- Speed sensing from alternator voltage or magnetic pickup;
- Configurable 3 inputs and 6 outputs;
- ECU powers, ECU stop, STOP or fuel solenoid selection;
- Automatic transfer switching control and engine control;
- Adjustable start, load and stop timers.



## SPECIFICATION

- Dimensions: 111mm\*81mm\*61mm
- Protection: IP65 at front panel
- Operating temperature: -20 °C to 70 °C
- Max. Operating current is 360mA
- Sender measurement: 0 to 1300 ohm
- Panel cut-out: 81mm\*70mm
- Weight: approximately 0.3kg
- DC battery supply voltage: 8 to 32Vdc
- CT secondary: 5A
- Accuracy: 1%FS, resolution: 1 ohm

## FUNCTION

- Pre-Alarm
- Engine temperature
- Oil pressure
- Over/under voltage
- Over/under frequency
- Over/under speed
- Warning & Electrical trip
- Over current
- Short circuit
- Error
- Over/under speed
- Speed loss
- Battery low
- Battery high
- Maintenance
- Over current
- Short circuit
- Engine stop
- Can bus
- Charge alternator
- Fail monitoring
- Emergency stop
- Multiple engage fail
- Failed to start
- Low oil pressure
- High temperature
- Speed failure
- Voltage
- Charging fail
- Shutdown
- Warning
- Controls
- Fuel and stop solenoid
- ECU power and stop
- Starter motor
- Automatic generator start
- Preheat
- External alarm horn
- Engine cooling
- Idle mode

Control System function list				
	MODEL	PLC-920	PLC-7420	
General accessory	AVR	●	●	
	Electronic Governing	×	×	
	Glow plug control	●	●	
	Cycle Cranking	●	●	
	(MODBUS) Networking	×	●	
	Fault History	●	●	
Operator Interface	manual start/stop	●	●	
	Auto/remote start	●	●	
	Regular test	●	●	
	Auto operation LED	●	●	
	Manual operation LED	●	●	
	Common Shutdown LED	●	●	
	Common warning LED	●	●	
	Fail to start LED	●	●	
	Emergency stop(local)	●	●	
	Alphanumeric screen	●	●	
Measurement and Its Transmission	Remote start input active LED	×	●	
	Alarm reset	●	●	
	Engine	Oil pressure	●	●
		Water Temperature	●	●
		Engine Speed	●	●
		Hours Run	●	●
		Number of Starts	●	●
	Alternator	Battery Voltage	●	●
		Coolant Temperature	●	●
		3Phase-L Voltage&Frequency	●	●
		3phase Current	●	●
		Frequency	●	●
		kWh	●	●
		Apparent Power	●	●
		Active Power and Reactive Power	●	●
		Power Factor	●	●
		Per PhasekW, kVAr	●	●
		Per Phase kVA	●	●
		Phase Voltage	●	●
		Output Power	×	●
Grid Line Voltage		×	●	
Grid Phase Voltage		×	●	
Grid Frequency	×	●		
Shutdown Protection and Indication	Low Fuel Level	●	●	
	High Fuel Level	×	○	
	Low Oil Pressure	●	●	
	High Water Temperature	●	●	
	Failure to Stop	●	●	
	Failure to Start	●	●	
	Controlable start circles/times	×	●	
	Overspeed	●	●	
	Under&Over Voltage	●	●	
	Under&Over Frequency	●	●	
Threshold Warning/Indication	Overcurrent	●	●	
	Earth Leakage	○	○	
	Reverse Power	×	×	
	Reverse kW	×	×	
	Low Oil Pressure	●	●	
	Low Water Temperature	○	○	
	High Water Temperature	●	●	
	Low Water Level	●	●	
	Low/High Battery Voltage	●	●	
	Failure to Charge	●	●	
Paralleling Capability	Overcurrent	●	●	
	Overload	●	●	
	genset Under/Over Voltage	●	●	
	genset Under/Over Frequency	●	●	
	under/over Speed	●	●	
	High Engine Temperature	●	●	
	Earth Leakage	○	○	
Power Transfer Function	Synchroscope(Independent Bus)	×	×	
	Active and Reactive Power Control	×	×	
	Synchroscope(Shared Bus)	×	×	
	Synchronization Detector	×	×	
	Peak Lopping	×	×	
	Automatic Transfer	○	●	
	Hard Closed Transition	●	●	
	Soft Closed Transition	×	×	
	Gen/Mains Breaker	×	●	
	Gen/Mains Breaker Status Protection	×	●	
Environment	Speed/Voltage Control	×	×	
	Power Indication	×	●	
	Fuel&Solenoid Valve Control	●	●	
	Starter Control	●	●	
	Preheating	○	○	
	Mains Transfer Switch (Standard)	×	●	
	Mains Transfer Switch (Emergency)	×	●	
	Operating Temperature (-40 °C - 70 °C)	●	●	
	Ambient Temperature (-25 °C - 45 °C)	●	●	
	Humidity ≤ 80%	●	●	
Monitoring Function	Grid Over/Under Voltage Control	×	●	
	Grid Over/Under Frequency Control	×	●	
	Remote Start Output(Load/No-load)	●	●	
	Optional Relay Output	●	●	
	Remote Telecom Control with All Functions	×	●	
	Engine Instrument Monitoring	●	●	
	Alternator Output Instrument Monitoring	●	●	
	Connection Point with All-around Setting For 4 Users	●	●	
	3 Users Input Connection Point	●	●	
	LCD Light Control of Low Light Operation Environment	●	●	
Monitoring Function	Safe PIN Code	●	●	
	RS232/485 Interface	×	●	
	Language Selection	●	●	
	Multi-Language Function	●	●	

# Control System

**Digital, intelligent control system allows easier operation.**

## PLC-7420

PLC-7420 is an advanced control module based on micro-processor, containing all necessary functions for protection of the genset and the breaker control. It can monitor the mains supply, breaker control and automatically start the engine when the mains is abnormal. Accurately measure various operational parameters and display all values and alarms information on the LCD. In addition, the control module can automatically shut down the engine and indicate the engine failure.



### FEATURES

- Microprocessor control, with high stability and credibility
- Monitoring and measuring operational parameters of the mains supply and genset
- Indicating operation status, fault conditions, all parameters and alarms
- Multiple protections; multiple parameters display, like pressure, temp. etc.
- Manual, automatic and remote work mode selectable
- Real time clock for time and date display, overall runtime display, 250 log entries
- Overall power output display
- Integral speed/frequency detecting, telling status of start, rated operation, overspeed etc.
- Communication with PC via RS485 OR RS232 interface, using MODBUS protocol

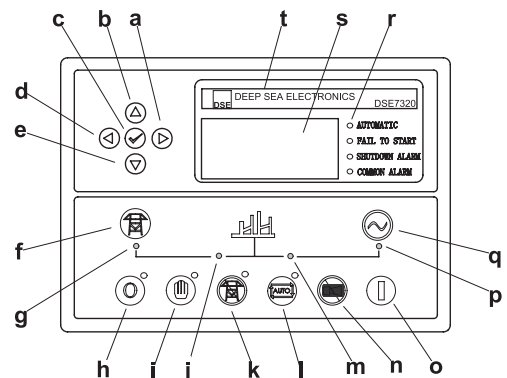

**Control Panel**

- a Button (next page)
- b Button (increase value / previous item)
- c Button (accept)
- d Button (previous page)
- e Button (decrease value / next item)
- f Button (transfer the load to the mains supply, when in Manual mode only)
- g Mains supply available LED
- h Stop / Reset button
- i Manual button (Manual control mode)
- j Mains supply on load LED
- k Test button (Test mode)
- l Auto button (Auto mode)
- m Genset on load LED
- n Mute/Lamp test button
- o Start button (Manual)
- p Genset available LED
- q Button (transfer the load to the genset, when in Manual mode only)
- r Alarm LED (4 alarm items)
- s LCD display
- t Control module name

## Optional

Engine	Alternator	Generator Set	Fuel System	Canopy
<ul style="list-style-type: none"> <li>• Water Jacket Preheater</li> <li>• Oil Preheater</li> </ul>	<ul style="list-style-type: none"> <li>• Winding Temperature Measuring Instrument</li> <li>• Alternator Preheater</li> <li>• PMG</li> <li>• Anti-damp and anti-corrosion treatment</li> <li>• Anti-condensation heater</li> </ul>	<ul style="list-style-type: none"> <li>• Tools with the machine</li> </ul>	<ul style="list-style-type: none"> <li>• Low fuel level alarm</li> <li>• Automatic fuel feeding system</li> <li>• Fuel T-valves</li> </ul>	<ul style="list-style-type: none"> <li>• Trailer</li> </ul>
Lubricating System	Exhaust System	Cooling System	Control Panel	Voltages
<ul style="list-style-type: none"> <li>• Oil with the machine</li> </ul>	<ul style="list-style-type: none"> <li>• Protection board from hotness</li> </ul>	<ul style="list-style-type: none"> <li>• Front heat protection</li> <li>• Coolant (-30°C)</li> </ul>	<ul style="list-style-type: none"> <li>• Remote control panel</li> <li>• PLC-920</li> <li>• PLC-7420</li> <li>• ATS</li> </ul>	<ul style="list-style-type: none"> <li>• 415/240V</li> <li>• 400/230V</li> <li>• 380/220V</li> <li>• 220/127V</li> <li>• 200-115V</li> </ul>

